

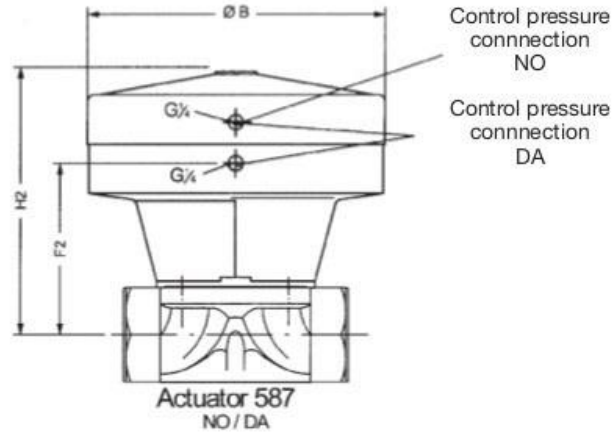

# 2/2 way metal diaphragm valve Typ 385 / 587

DN 15 - DN 80 / 1/2" - 3"

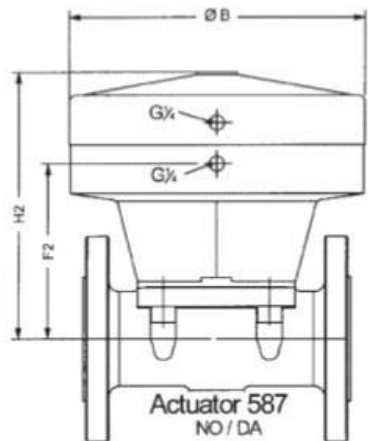
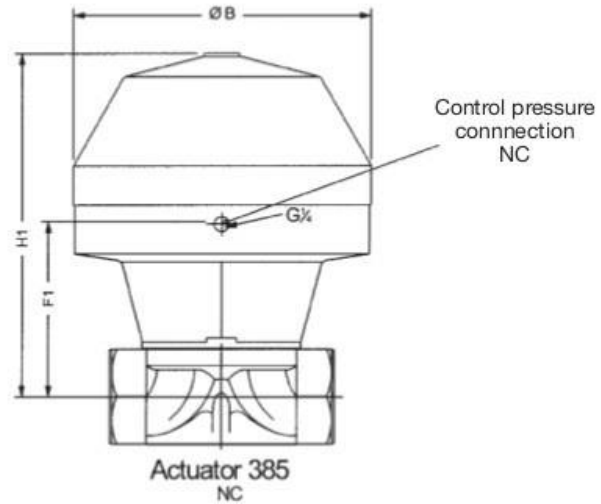
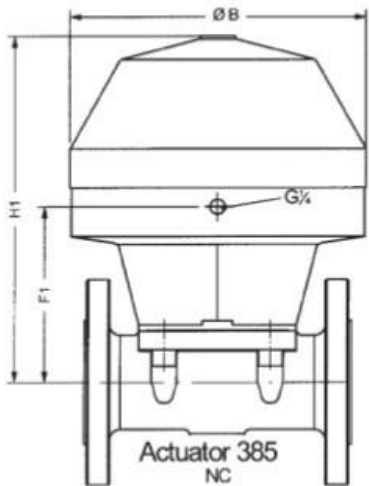

DN mm	Size inch	Type 385 Face to Face								Type 587 Face to Face								Type 385 with Threaded Socket								Type 587 with Threaded Socket							
		Ø B		F1		H1		Lbs.	Kg	F2		H2		Lbs.	Kg	F1		H1		Lbs.	Kg	F2		H2		Lbs.	Kg						
		mm	Inch	mm	Inch	mm	Inch			mm	Inch	mm	Inch			mm	Inch	mm	Inch			mm	Inch	mm	Inch								
15	1/2	130	5.11	66	2.59	160	6.3	6.8	3.1	95	3.74	128	5.04	4.6	2.1	57	2.24	151	5.94	4.2	1.9	86	3.39	119	4.69	4.2	1.9						
20	3/4	130	5.11	66	2.59	160	6.3	8.2	3.7	95	3.74	128	5.04	6.0	2.7	60	2.36	154	6.06	4.4	2.0	89	3.5	122	4.80	4.4	2.0						
25	1	130	5.11	70	2.76	160	6.3	9.3	4.2	95	3.74	129	5.04	7.1	3.2	64	2.52	154	6.06	5.1	2.3	89	3.5	123	4.84	5.1	2.3						
32	1 1/4	161	6.33	108	4.25	208	8.19	17	7.7	134	5.28	167	6.57	14.8	6.7	104	4.09	204	8.03	9.9	4.5	130	5.12	163	6.42	9.9	4.5						
40	1 1/2	161	6.33	108	4.25	213	8.39	18.1	8.2	134	5.28	171	6.73	15.9	7.2	101	3.98	206	8.11	10.8	4.9	127	5.0	164	6.46	10.8	4.9						
50	2	218	8.58	127	5.00	263	10.35	29.1	13.2	159	6.26	203	7.99	28.0	12.7	123	4.84	259	10.20	19.0	8.6	155	6.1	199	7.83	19	8.6						
65	2 1/2	265	10.43	182	7.17	330	12.99	57.3	26	225	8.86	291	11.5	51.6	23.4																		
80	3	265	10.43	182	7.17	330	12.99	57.3	26	225	8.86	291	11.5	51.6	23.4																		

01006 Rev. 1 Subject to alteration.

